



Features

- Wide 5V to 32V Input Voltage Range
- Output Adjustable from 0.8V to 30V
- Maximum Duty Cycle 100%
- Minimum Drop Out 0.6V
- Fixed 300KHz Switching Frequency
- 5A Constant Output Current Capability
- Internal Optimize Power MOSFET
- High efficiency
- Excellent line and load regulation
- TTL shutdown capability
- EN pin with hysteresis function
- Built in thermal shutdown function
- Built in current limit function
- Built in output short protection function
- Available in TO-263 package

Applications

- LCD Monitor and LCD TV
- Digital Photo Frame
- Set-up Box
- ADSL Modem
- Telecom / Networking Equipment

General Description

The XL4005 is a 300KHz fixed frequency PWM buck (step-down) DC/DC converter, capable of driving a 5A load with high efficiency, low ripple and excellent line and load regulation. Requiring a minimum number of external components, the regulator is simple to use and include internal frequency compensation and a fixed-frequency oscillator.

The PWM control circuit is able to adjust the duty ratio linearly from 0 to 100%. An enable function, an over current protection function is built inside. When short protection function happens, the operation frequency will be reduced from 300KHz to 60KHz. An internal compensation block is built in to minimize external component count.



Figure1. Package Type of XL4005



Pin Configurations

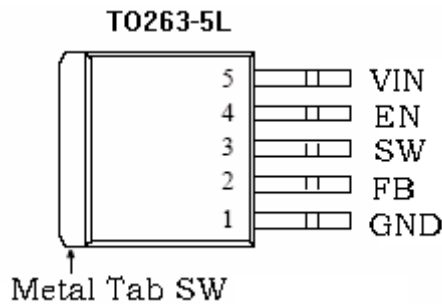

Figure2. Pin Configuration of XL4005 (Top View)

Table 1 Pin Description

Pin Number	Pin Name	Description
1	GND	Ground Pin. Care must be taken in layout. This pin should be placed outside of the Schottky Diode to output capacitor ground path to prevent switching current spikes from inducing voltage noise into XL4005.
2	FB	Feedback Pin (FB). Through an external resistor divider network, FB senses the output voltage and regulates it. The feedback threshold voltage is 0.8V.
3	SW	Power Switch Output Pin (SW). SW is the switch node that supplies power to the output.
4	EN	Enable Pin. Drive EN pin high to turn on the device, drive it low to turn it off.
5	VIN	Supply Voltage Input Pin. XL4005 operates from a 5V to 32V DC voltage. Bypass Vin to GND with a suitably large capacitor to eliminate noise on the input.



5A 300KHz 32V Buck DC to DC Converter **XL4005**

Function Block

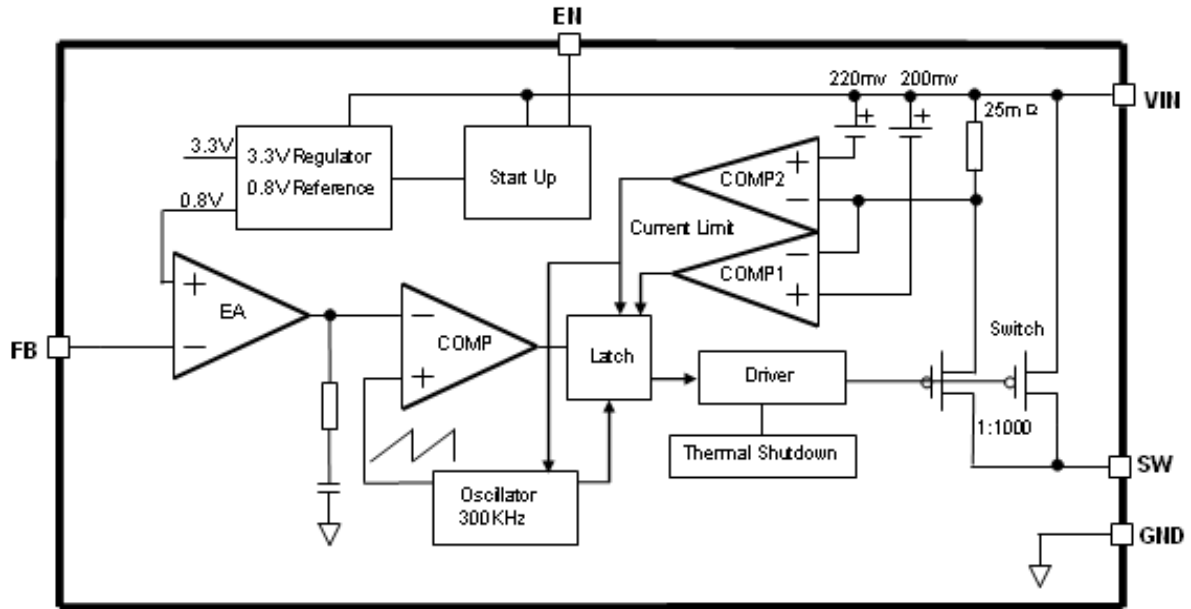

Figure3. Function Block Diagram of XL4005

Typical Application Circuit

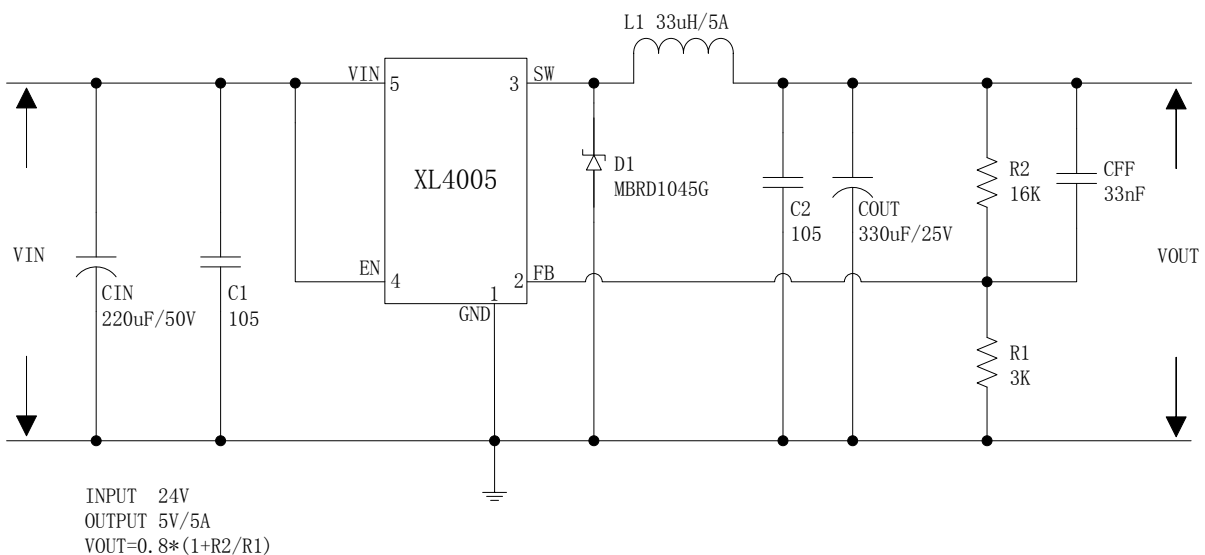

Figure4. XL4005 Typical Application Circuit (24V~5V/5A)



Ordering Information

Order Information	Marking ID	Package Type	Packing Type Supplied As
XL4005E1	XL4005E1	TO263-5L	800 Units on Tape & Reel

XLSEMI Pb-free products, as designated with “E1” suffix in the par number, are RoHS compliant.

Absolute Maximum Ratings (Note1)

Parameter	Symbol	Value	Unit
Input Voltage	V_{in}	-0.3 to 35	V
Feedback Pin Voltage	V_{FB}	-0.3 to V_{in}	V
EN Pin Voltage	V_{EN}	-0.3 to V_{in}	V
Output Switch Pin Voltage	V_{Output}	-0.3 to V_{in}	V
Power Dissipation	P_D	Internally limited	mW
Thermal Resistance (TO263) (Junction to Ambient, No Heatsink, Free Air)	R_{JA}	30	$^{\circ}C/W$
Operating Junction Temperature	T_J	-40 to 125	$^{\circ}C$
Storage Temperature	T_{STG}	-65 to 150	$^{\circ}C$
Lead Temperature (Soldering, 10 sec)	T_{LEAD}	260	$^{\circ}C$
ESD (HBM)		2000	V

Note1: Stresses greater than those listed under Maximum Ratings may cause permanent damage to the device. This is a stress rating only and functional operation of the device at these or any other conditions above those indicated in the operation is not implied. Exposure to absolute maximum rating conditions for extended periods may affect reliability.



XL4005 Electrical Characteristics

$T_a = 25^\circ\text{C}$; unless otherwise specified.

Symbol	Parameter	Test Condition	Min.	Typ.	Max.	Unit
<i>System parameters test circuit figure4</i>						
VFB	Feedback Voltage	$V_{in} = 5V \text{ to } 32V, V_{out}=5V$ $I_{load}=0.5A \text{ to } 5A$	0.776	0.8	0.824	V
Efficiency	η	$V_{in}=12V, V_{out}=5V$ $I_{out}=5A$	-	90	-	%

Electrical Characteristics (DC Parameters)

$V_{in} = 12V, GND=0V, V_{in}$ & GND parallel connect a $220\mu\text{f}/50V$ capacitor; $I_{out}=500\text{mA}, T_a = 25^\circ\text{C}$; the others floating unless otherwise specified.

Parameters	Symbol	Test Condition	Min.	Typ.	Max.	Unit
Input operation voltage	V_{in}		5		32	V
Shutdown Supply Current	I_{STBY}	$V_{EN}=0V$		60	200	μA
Quiescent Supply Current	I_q	$V_{EN}=2V,$ $V_{FB}=V_{in}$		3	5	mA
Oscillator Frequency	F_{osc}		240	300	360	Khz
Switch Current Limit	I_L	$V_{FB}=0$		8		A
EN Pin Threshold	V_{EN}	High (Regulator ON) Low (Regulator OFF)		1.4 0.8		V
EN Pin Input Leakage Current	I_H	$V_{EN}=2V$ (ON)		1	15	μA
	I_L	$V_{EN}=0V$ (OFF)		1	15	μA
Max. Duty Cycle	D_{MAX}	$V_{FB}=0V$		100		%



Test Circuit and Layout guidelines

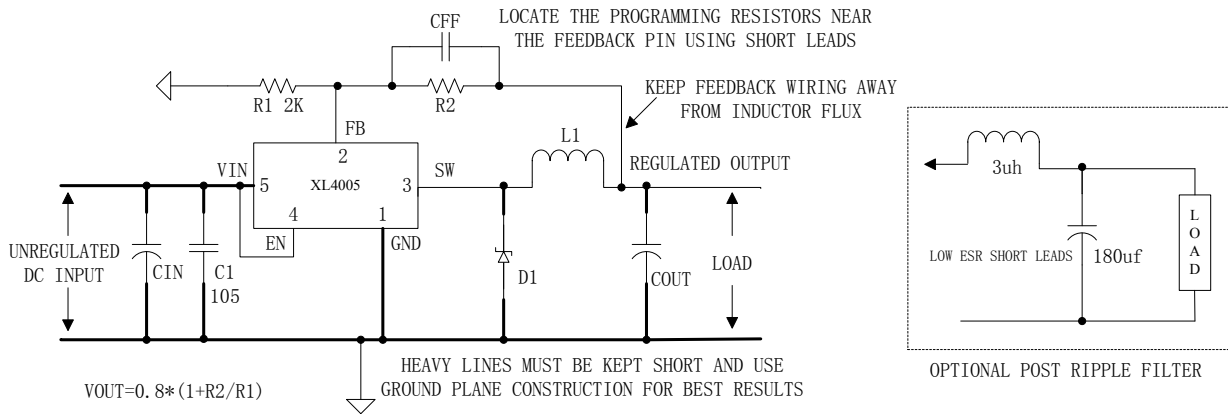

Figure5. Standard Test Circuits and Layout Guides

Select R1 to be approximately 2K, use a 1% resistor for best stability.

C1 and CFF are optional; in order to increase stability and reduce the input power line noise, CIN and C1 must be placed near to VIN and GND;

For output voltages greater than approximately 10V, an additional capacitor CFF is required. The compensation capacitor is typically between 100 pf and 33 nf, and is wired in parallel with the output voltage setting resistor, R2. It provides additional stability for high output voltage, low input-output voltages, and/or very low ESR output capacitors, such as solid tantalum capacitors. $CFF = 1 / (31 * 1000 * R2)$; This capacitor type can be ceramic, plastic, silver mica, etc. (Because of the unstable characteristics of ceramic capacitors made with Z5U material, they are not recommended.)



5A 300KHz 32V Buck DC to DC Converter **XL4005**

Typical System Application for 24V ~ 12V/4A Version

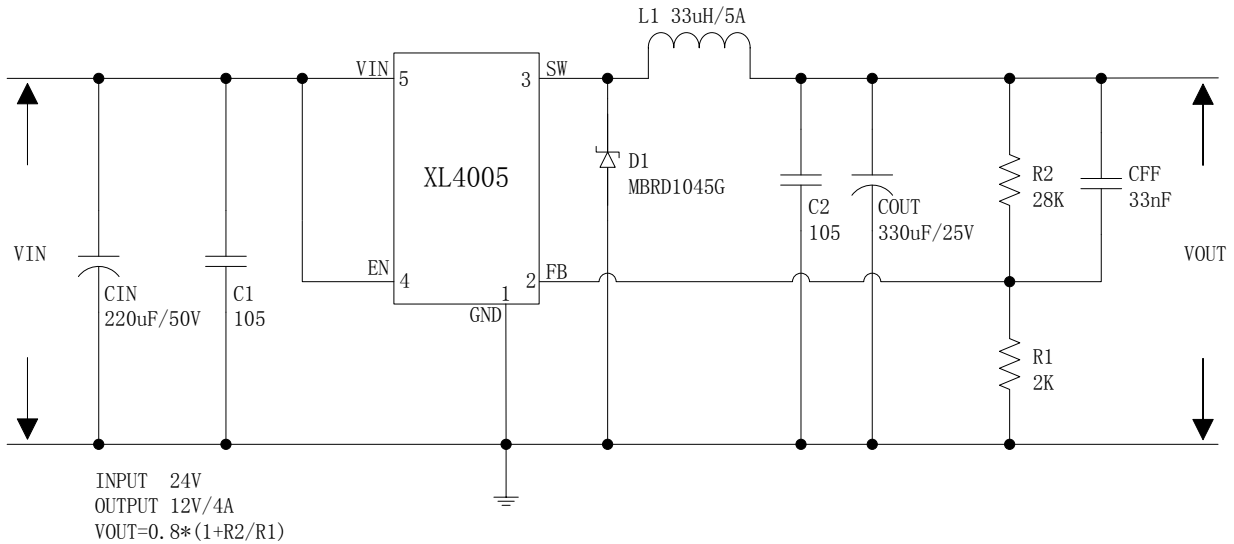

Figure6. XL4005 System Parameters Test Circuit (24V ~ 12V/4A)

Typical System Application for 24V ~ 5V/5A

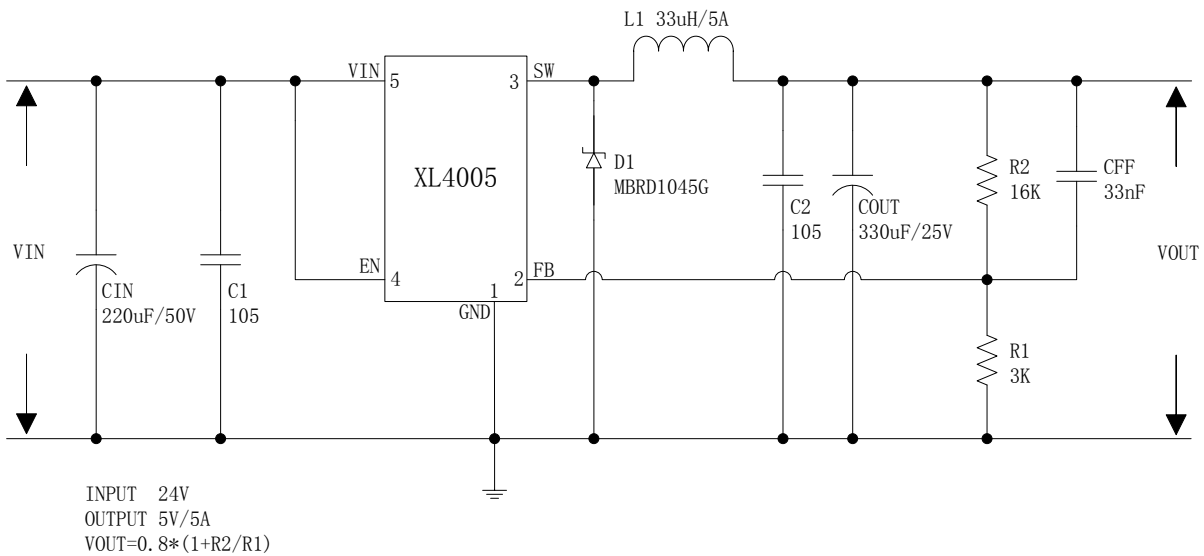
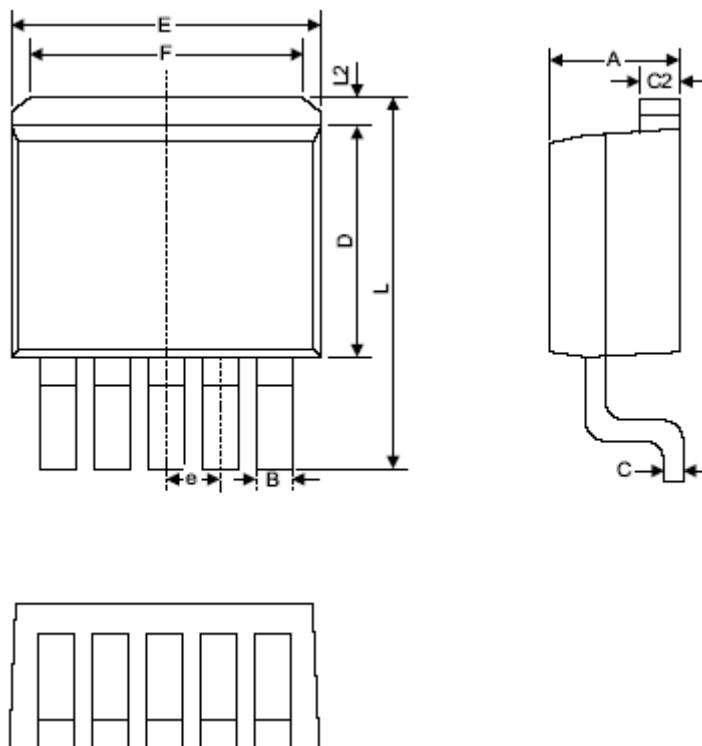

Figure7. XL4005 System Parameters Test Circuit (24V ~ 5V/5A)



Package Information

TO263-5L



Symbol	Dimensions In Millimeters		Dimensions In Inches	
	Min	Max	Min	Max
A	4.06	4.83	0.160	0.190
B	0.71	1.02	0.030	0.040
C	0.36	0.64	0.014	0.025
C2	1.14	1.40	0.045	0.055
D	8.39	9.65	0.330	0.380
E	9.78	10.54	0.385	0.415
e	1.55	1.85	0.061	0.073
F	6.36	7.36	0.250	0.290
L	13.95	15.37	0.549	0.605
L2	1.12	1.42	0.044	0.056