

SHARP

1. These specification sheets include materials protected under copyright of Sharp Corporation ("Sharp").
Please handle with great cares and do not reproduce or cause anyone to reproduce them without Sharp's consent.
2. When using this Sharp product, please observe the absolute maximum ratings, other conditions and instructions for use described in the specification sheets, as well as the precautions mentioned below.
Sharp assumes no responsibility for any damages resulting from use of the product which does not comply with absolute maximum ratings, other conditions and instructions for use included in the specification sheets, and the precautions mentioned below.

(Precautions)

- (1) In making catalogue or instruction manual based on the specification sheets, please verify the validity of the catalogue or instruction manuals after assembling Sharp products in customer's products at the responsibility of customer.
- (2) This Sharp product is designed for use in the following application areas ;
 - Computers • OA equipment • Telecommunication equipment (Terminal) • Measuring equipment
 - Tooling machines • Audio visual equipment • Home appliances
 If the use of the Sharp product in the above application areas is for equipment listed in paragraphs (3) or (4), please be sure to observe the precautions given in those respective paragraphs.
- (3) Appropriate measures, such as fail-safe design and redundant design considering the safety design of the overall system and equipment, should be taken to ensure reliability and safety when Sharp product is used for equipment in responsibility of customer which demands high reliability and safety in function and precision, such as ;
 - Transportation control and safety equipment (aircraft, train, automobile etc.)
 - Traffic signals • Gas leakage sensor breakers • Rescue and security equipment
 - Other safety equipment
- (4) Sharp product is designed for consumer goods and controlled as consumer goods in production and quality.
Please do not use this product for equipment which require extremely high reliability and safety in function and precision, such as ;
 - Space equipment • Telecommunication equipment (for trunk lines)
 - Nuclear power control equipment • Medical equipment
- (5) Please contact and consult with a Sharp sales representative if there are any question regarding interpretation of the above four paragraphs.

3. Disclaimer

The warranty period for Sharp product is one (1) year after shipment.
During the period, if there are any products problem, Sharp will repair (if applicable), replace or refund.
Except the above, both parties will discuss to cope with the problems.

The failed Sharp product after the above one (1) year period will be coped with by Sharp, provided that both parties shall discuss and determine on sharing responsibility based on the analysis results thereof subject to the above scope of warranty.

The warranty described herein is only for Sharp product itself which are purchased by or delivered to customer.
Damages arising from Sharp product malfunction or failure shall be excepted.

Sharp will not be responsible for the Sharp product due to the malfunction or failures thereof which are caused by:

- (1) storage keep trouble during the inventory in the marketing channel.
- (2) intentional act, negligence or wrong/poor handling.
- (3) equipment which Sharp products are connected to or mounted in.
- (4) disassembling, reforming or changing Sharp products.
- (5) installation problem.
- (6) act of God or other disaster (natural disaster, fire, flood, etc.)
- (7) external factors (abnormal voltage, abnormal electromagnetic wave, fire, etc.)
- (8) special environment (factory, coastal areas, hot spring area, etc.)
- (9) phenomenon which cannot be foreseen based on the practical technologies at the time of shipment.
- (10) the factors not included in the product specification sheet.

4. Please contact and consult with a Sharp sales representative for any questions about Sharp product.

1. Application

This specification sheets applies to the outline and characteristics of reflective type proximity sensor
; Model No. GP2AP110S00F

2. Outline Refer to the drawing page 5.
3. Ratings and characteristics Refer to the Page 6 .
4. Outgoing inspection Refer to the Page 7.
5. Supplement

1) This product is built-in photodiode.

2) Brominated flame retardants

Specific brominated flame retardants such as the PBB and PBDE are not used in this device at all.

3) This product shall not contain the following materials.

Also, the following materials shall not be used in the production process for this product.

Materials for ODS : CFCs, Halon, Carbon tetrachloride, 1,1,1-Trichloroethane (Methylchloroform)

4) Compliance with each regulation

5.4.1 This product complies with EU RoHS Directive (2011/65/EU) and
Commission Delegated Directive (EU)2015/863

5.4.2 Content of six substances specified in Management Methods for Control of Pollution Caused by Electronic
Information Products Regulation (Chinese : 电子信息产品污染控制管理办法).

Marking Styles for the Names and Contents of the Hazardous Substances

Category	Hazardous Substances					
	Lead (Pb)	Mercury (Hg)	Cadmium (Cd)	Hexavalent chromium (Cr ⁶⁺)	Polybrominated biphenyls (PBB)	Polybrominated diphenyl ethers (PBDE)
Proximity	○	○	○	○	○	○

This table is prepared in accordance with the provisions of SJ/T 11364.

○ : Indicates that said hazardous substance contained in all of the homogeneous materials for this part is
below the limit requirement of GB/T 26572

5) Product mass : Approx . 0.013 g

6) Production site : China

7) The moisture absorption level of this product is MSL.3.

6. Notes

1) Notes concerning receiver surface

Please note enough that it is likely to malfunction when a receiver surface is dirty with garbage and dust, etc.

Moreover, please do not touch a receiver surface.

2) For cleaning

Cleaning shall carry out as the below items to avoid keeping solvent, solder and flux on the device.

- Solvent cleaning : Solvent temperature 45°C or less, Immersion for 3 min or less
- Ultrasonic cleaning : Please don't carry out ultrasonic cleaning.
- The cleaning shall be carried out with solvent below.

Solvent : Ethyl alcohol, Methyl alcohol, Isopropyl alcohol

3) Please take proper methods to prevent ESD. The IC built in GP2AP110S00F is ESD-sensitive because it is fabricated by sub-micron CMOS process. For example, in handling GP2AP110S00F, human body and soldering iron etc. should be grounded.

4) Before the circuit design

In circuit designing, make allowance for the degradation of the light emitting diode output that results from long continuous operation. (50% degradation/5 years)

5) Notes ambient light

Proximity mode when set to avoid malfunctions due to a strong disturbance light, such an arrangement to receive ambient light Directly on the detector, please be avoided. Also by placing this product in close proximity to other components, it may be a malfunction with the light reflected from their product, structural arrangement to reduce the amount of light receiving surface of the outer, please consider.

- 6) After being mounted and soldered, if GP2AP110S00F is deformed by external force or impact, e.g. something falls onto the device, it may result in defective implementation such as lift-off of the terminals. Careful handling should be taken.
- 7) For soldering
Refer to Page 8.
- 8) Eye Safety Considerations

GP2AP110S00F contains a VCSEL (laser emitter) and corresponding drive circuitry. The VCSEL output is Class 1 laser safety under all reasonably foreseeable including single faults in compliance with IEC 60825-1:2014. The VCSEL output will remain within Class 1 limits as long as the Sharp recommended device settings are used and the operating conditions specified in this datasheet are respected. The laser output power must not be increased by any means and no optics should be used with the intention of focusing the laser beam.



※Shut down the VCSEL power supply when the VCSEL fail-safe signal occurs. For details, refer to the attached document.

9) Recommended external circuit

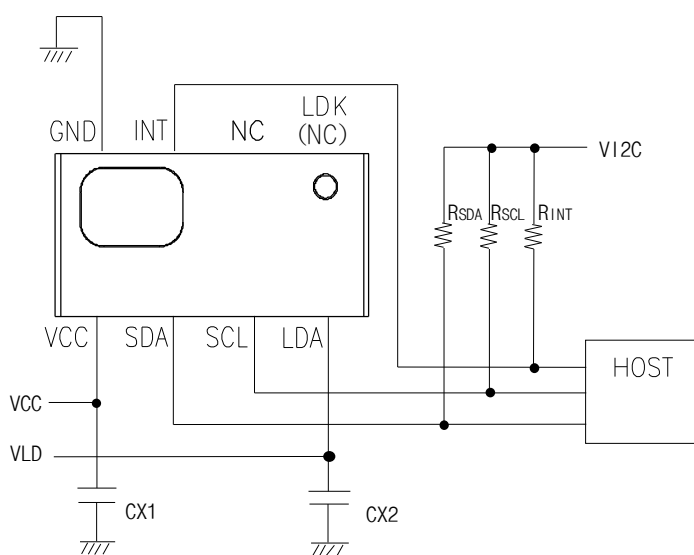

Components	Recommended values
CX1	1 μ F
CX2	1 μ F
R _p	22 Ω
R _{SDA}	10k Ω
R _{SCL}	10k Ω
R _{INT}	10k Ω

There are cases to generate a noise because LD driving current flows LDA terminal, and to distort a waveform of LD driving current.

To reduce these influences, please arrange CX2 within 5mm from LDA terminal, and wire between LDA terminal, CX2 and GND terminal as close as possible. Also, the wiring of VLED is separated from VCC and V12C terminals, and the power source of VLD is separated from VCC is recommended.

And in order to reduce the influence of the power supply noise, please arrange CX1 and R_p within 5mm from VCC terminal.

Please evaluate with the actual electrical implementation, and carefully make sure that there is no problem.

SDA terminal (as output) and INT terminal are NMOS open-drain output.

NC pin must be held open. (disconnected)

10) Block diagram

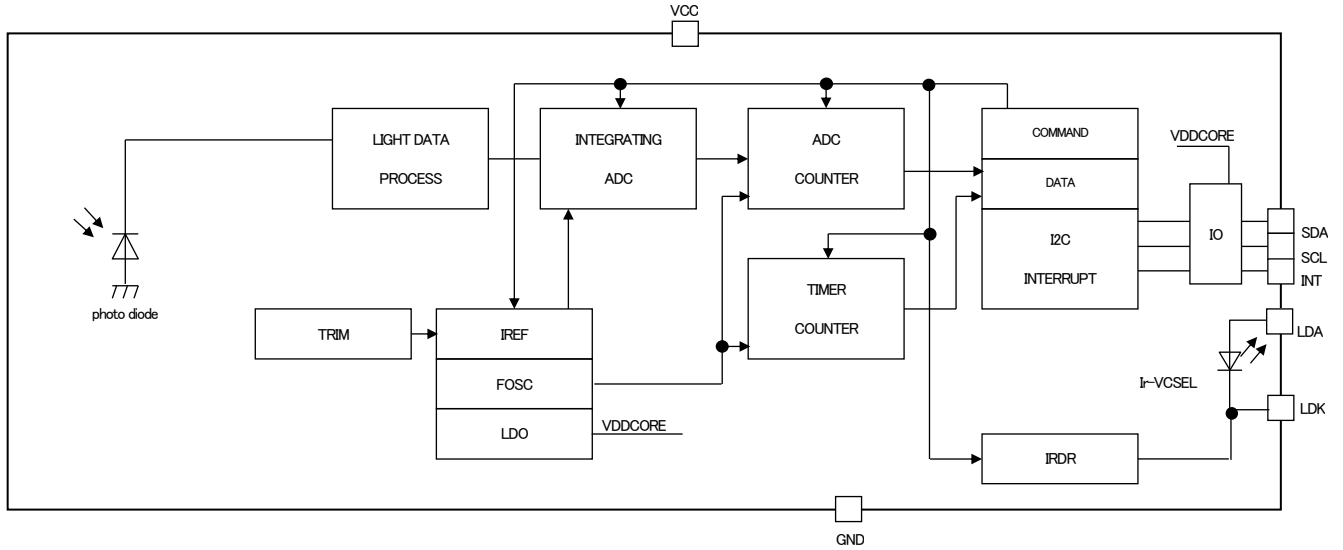

11) Foot pattern of PCB

(1) Dimensions are shown for reference.

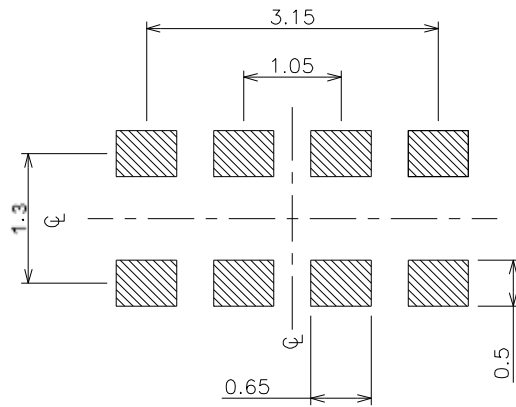

: Soldering paste area Unit: mm

(2) Recommendable size of solder creamed paste (Reference)

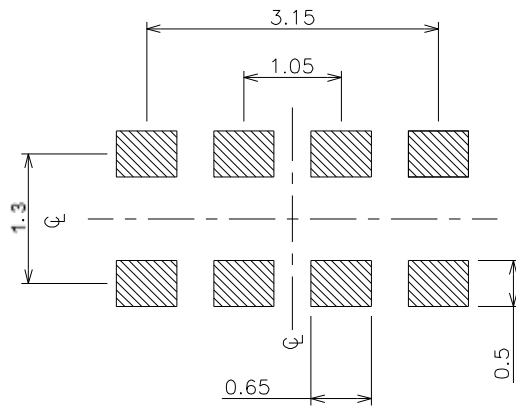

: Soldering paste area Unit: mm

2. Outline Dimensions

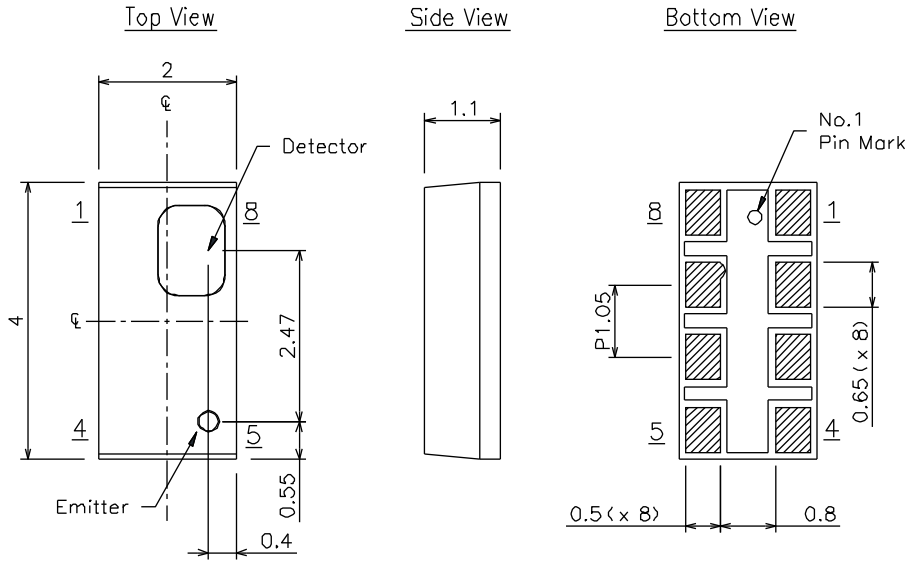

Unit : mm

(Note)

- (1) area : Au plating
- (2) Unspecified tolerance shall be ±0.1mm

Pin Description

Pin No.	Pin Name
1	VCC
2	SDA
3	SCL
4	LDA
5	LDK
6	NC
7	INT
8	GND

: Model Number
GP2AP110S00F = B S

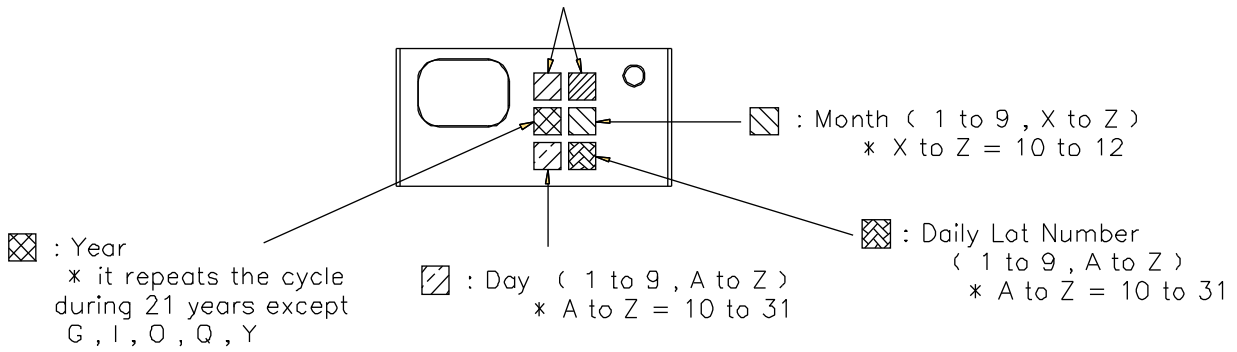

Year	Mark
2018	K
2019	L
2020	M
2021	N
⋮	⋮
2032	B
2033	C

Charts of the Days / Daily Lot Numbers

10	11	12	13	14	15
A	B	C	D	E	F
16	17	18	19	20	21
G	H	J	K	L	N
22	23	24	25	26	27
P	Q	R	S	T	U
28	29	30	31		
V	X	Y	Z		

Except I, M, O, W

SCALE	MATERIAL	FINISH	Name	DRAWING No.									
10/1	Terminal: Cu Package: Epoxy	Terminal: Ni, Au	GP2AP110S00F Outline Dimension	C	Y	1	5	7	8	0	i	0	2
UNIT													
1 = 1/1 mm													

3. Ratings and Characteristics

3.1 Absolute Maximum Ratings

Ta=25°C(unless otherwise specified)

Parameter	Symbol	Rating	Unit	Remarks
Power supply voltage	VCC	-0.3 to 3.8	V	
LD voltage	VLD	-0.3 to 3.8	V	
I2C voltage	VI2C	-0.3 to 3.8	V	
Operating temperature	Topr	-20 to 85	°C	
Storage temperature	Tstg	-40 to 85	°C	
Soldering temperature	Tsol	260	°C	peak temperature duration:10s

3.2 Recommended Operating Conditions

Ta=25°C(unless otherwise specified)

Parameter	Symbol	Operating condition	Unit	Remarks
Power supply voltage	VCC	1.7 to 3.6	V	
LD voltage	VLD	3.0 to 3.6	V	
I2C voltage	VI2C	1.7 to 3.6	V	
Operating temperature	Topr	-20 to 85	°C	
SCL, SDA input low level	VIL	-0.3 to 0.54	V	
SCL, SDA input high level	VIH	1.26 to Vcc+0.2	V	

3.3 Electrical and Optical Characteristics

Ta=25°C, VCC=VLED=VI2C=3.0V

(unless otherwise specified. The external circuit constants follow the recommended external circuit of page 4.)

Parameter	Symbol	Min.	Typ.	Max.	Unit	Remarks
Current consumption (PS)	I _{CC_PS}		130	230	μA	OP[1:0]=10
Current consumption (Power Down)	I _{CC_S}	—	—	5	μA	OP[3]=0
Internal Oscillator Frequency	f _{osc1}	—	2.0	—	MHz	
I2C clock frequency	f	1	—	400	kHz	
SDA output low level voltage	V _{OL_SDA}	0	—	0.4	V	I _{OL_SDA} =3mA
INT output low level voltage	V _{OL_INT}	0	—	0.4	V	I _{OL_INT} =3mA
ADC Conversion Time1 (PS)	T _{int_P}	—	2	—	ms	12bit ADC
Full scale ADC code1	Data_F _{PS}	—	—	16383	counts	
Dark counts	Data_DC	—	—	5	counts	RES_P[0]=1 IS[0]=1, SUM[2]=1,
Detection distance	L	90	100	110	mm	RES_P[0]=1 IS[0]=01, SUM[2]=1, Detection Object : KODAK Gray Card (white side / r=0.9) *1
LD peak wavelength	λ _{P_PS}	—	940	—	nm	
LD peak current	I _{LD1}	—	10	—	mA	IS[0]=01
	I _{LD2}	—	20	—	mA	IS[0]=10

Typical value is a reference value, there is no guarantee

*1. Detection distance (PS part)

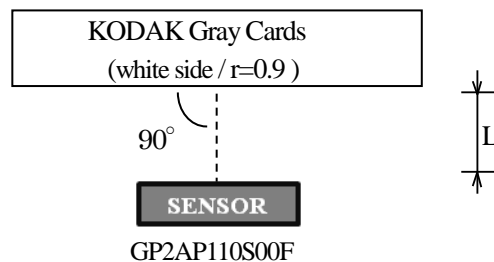

Under dark condition

4. Outgoing inspection

(1) Inspection lot

Inspection shall be carried out per each delivery lot.

(2) Inspection method

A single sampling plan, normal inspection level II based on ISO 2859 shall be adopted.

Parameter		Inspection items and test method		AQL(%)
Major defect	1	Disconnection, short		0.1
	2	Electrical characteristics defect in parameter 3.3		
Minor defect	1	Appearance defect		0.25
		Parameter	Judgment criteria	
		Split, Chip. Scratch Stain, Blur	One which affects the characteristics of Parameter 3.3 shall be defect.	

Precautions for Soldering

1. In case of solder reflow

Reflow is allowed only two at the temperature and the time within the temperature profile as shown in the figure below.

This Profile temperature is the sensor surface package temperature.

Reflow interval shall be within 7days under conditions, 10 to 30°C, 70%RH or less.

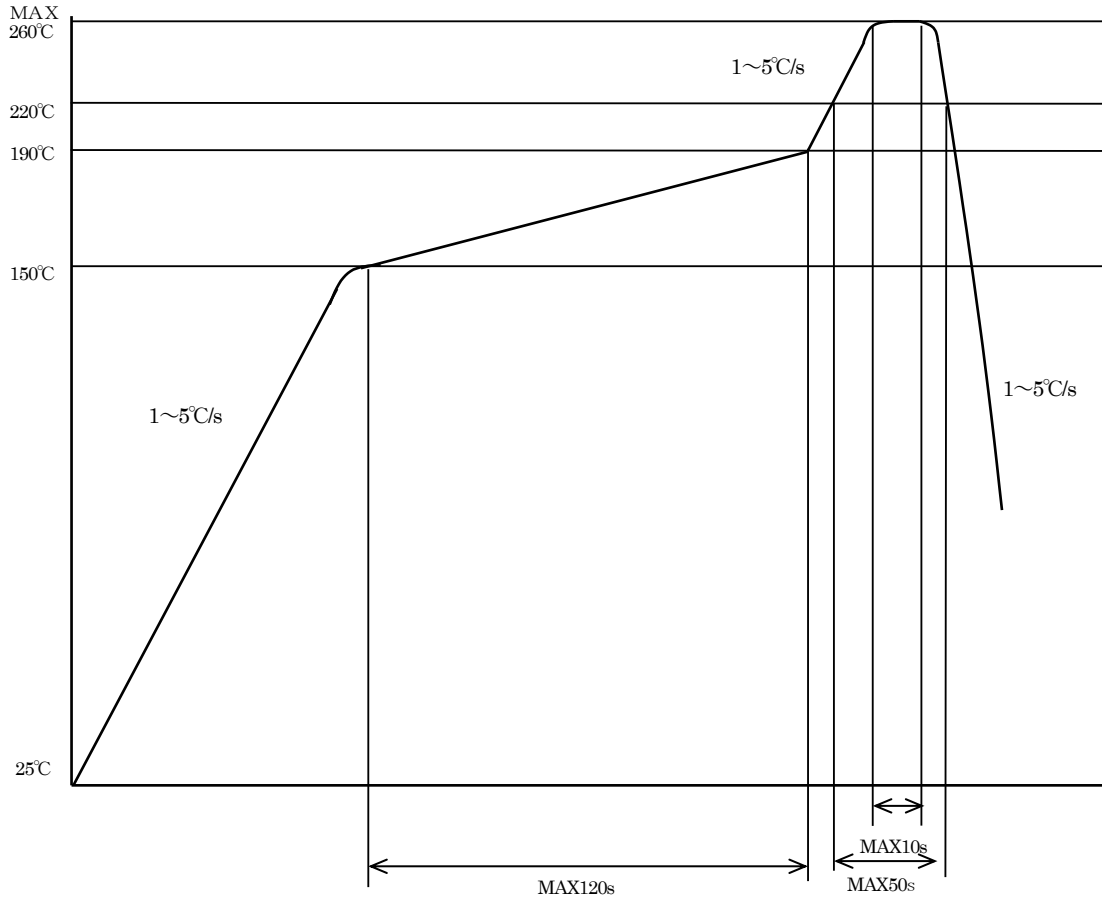

2. Other precautions

An infrared lamp used to heat up for soldering may cause a localized temperature rise in the resin.

Also avoid immersing the resin part in the soldering.

Even if within the temperature profile above, there is the possibility that the gold wire in package is broken in case that the deformation of PCB gives the affection to lead pins.

Please use after confirmation the conditions fully actual solder reflow machine.

Taping specifications

1. Application

This packing specification sheets specify the taping specifications for GP2AP110S00F.

2. Taping method

2-1.Tape structure and Dimensions (Refer to the attached sheet, page 10.)

The tape shall have a structure in which a cover tape is sealed pressed on the carrier tape of conductive Polycarbonate.

2-2.Reel structure and Dimensions (Refer to the attached sheet, page 11.)

The taping reel shall be conductive plastic with its dimensions as shown in the attached drawing.

2-3.Direction of product insertion (Refer to the attached sheet, page 11.)

The sensor direction in carrier tape shall be; the emitter of the sensor locates to the feeding hole side of the carrier tape and the sensor lens faces to the top of the pocket of the carrier tape.

2-4.The way to repair taped failure devices

The way to repair taped failure devices cut a bottom of carrier tape with a cutter, and after replacing to good devices, the cutting portion shall be sealed with adhesive tape.

3. Adhesiveness of cover tape

The exfoliation force between carrier tape cover tape shall be 0.2N to 1.2N for the angle from 160 degrees to 180 degrees.

4. Rolling method and quantity

Wind the tape back on the reel so that the cover tape will be outside the tape.
Attach 16cm or more of blank tape to the trailer and 40cm or more of blank tape to the leader and fix the both ends with adhesive tape.
One reel shall contain 2000pcs.
There must not be continuously two or more Stock-Outs.

5. Safety protection during shipping

There shall be no deformation of component or degradation of electrical characteristics due to shipping.

Taping moisture-proof packing

1. Application

This packing specification sheets apply to the moist-proof packing for the GP2AP110S00F in the taping package.

2. Packaging specifications

Packaging method

- (1) Fill necessary information to barcode labels.
- (2) Paste one of the barcode labels and a moisture indicator to a tape reel (contains 2,000 devices per reel).
- (3) Seal the aluminum laminated bag that contains the tape reel and siccative, and paste one of the barcode labels.
- (4) Pack 5 aluminum laminated bags (contains 1 reel each) into the designated packing case, where paper pads are placed on the bottom and top of the packing case, as well as each layer of the aluminum laminated bags.

Package shape	Product	Quantity	Moisture-proof sack Quantity
Tape reel (ϕ 180mm)	1 model	2000pcs. / reel *	1reel / laminated bag

Minimum order/shipment quantity should be 1 laminated bag.

- (5) The packing case would be then sealed with the craft tape, with barcode label (based on EIAJ C-3).
(Total of 10,000pcs. per carton) * Except for the case that device is removed.

2-1 Tape structure and Dimensions

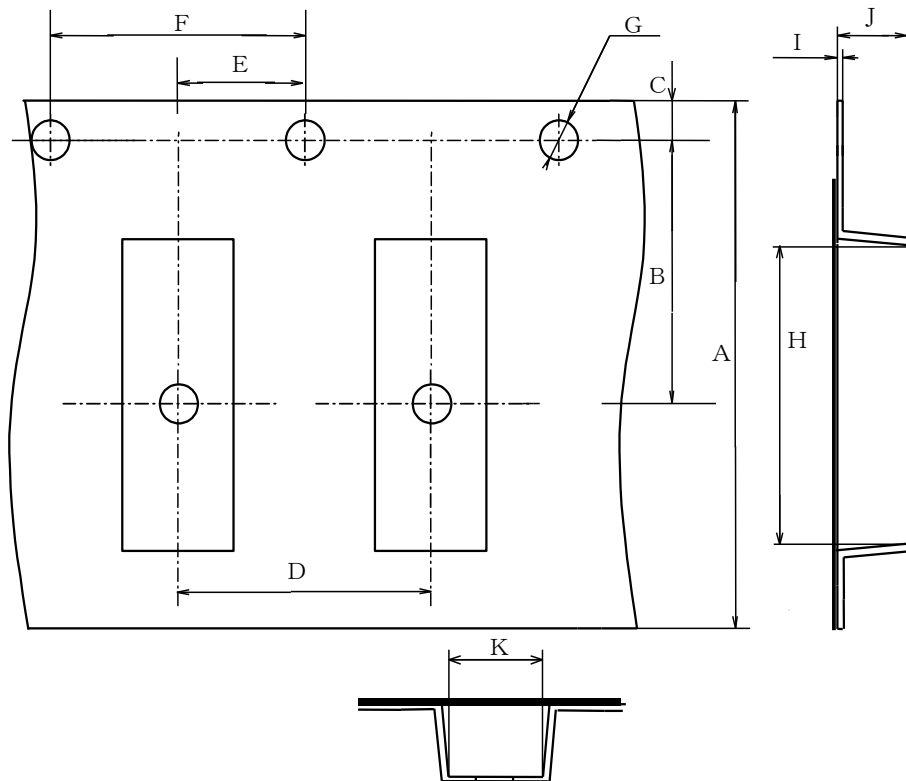

Symbol	A	B	C	D	E	F
Unit						
mm	± 0.3	± 0.1	± 0.1	± 0.1	± 0.1	± 0.1
	12.0	5.5	1.75	4.0	2.0	4.0

Symbol	G	H	I	J	K
Unit					
mm	ϕ 1.5	± 0.1	± 0.05	± 0.1	± 0.1
		4.3	0.25	1.4	2.2

2-2. Reel structure and Dimensions

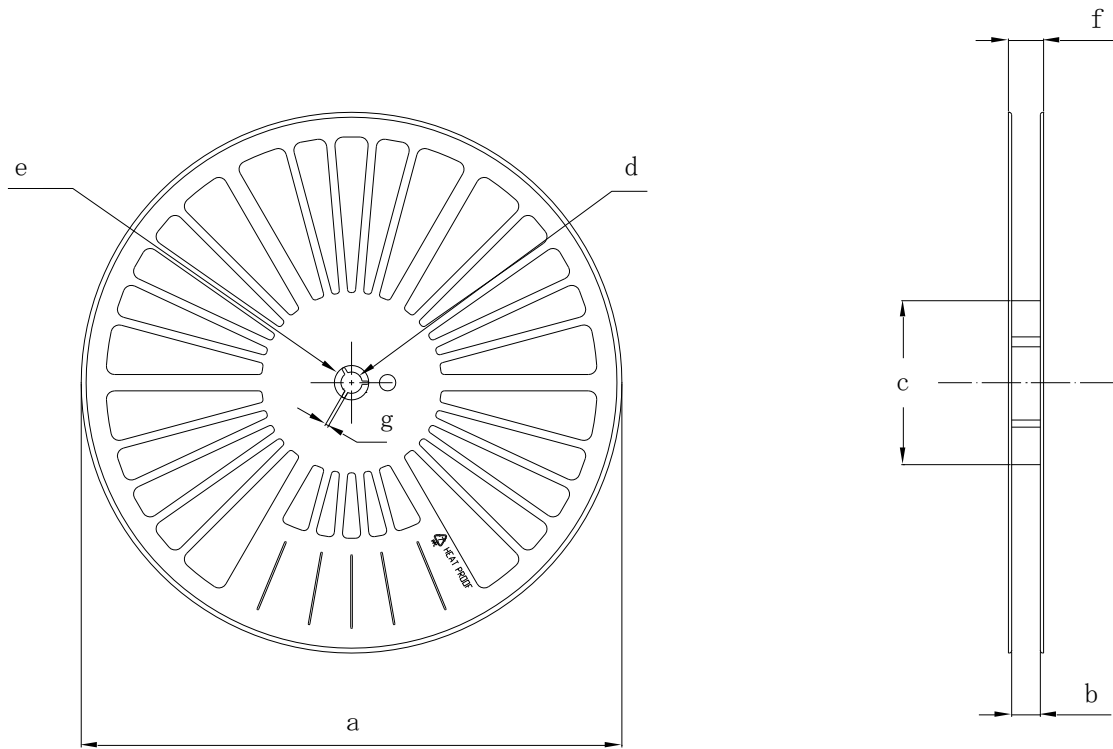

Symbol Unit	Check word						
	a	b	c	d	e	f	g
mm	$\phi 180 \pm 1.0$	13.5 ± 1.0	$\phi 100 \pm 1.0$	$\phi 13 \pm 0.2$	$\phi 21 \pm 0.8$	18.5 ± 1.0	2 ± 0.5

2-3. Direction of product insertion

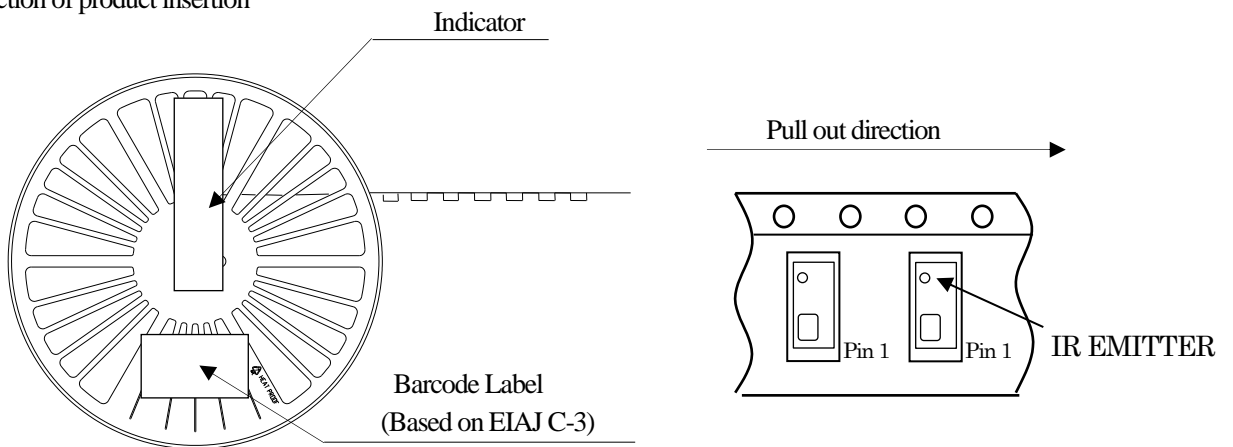

3. Storage and Treatment after Unsealed

3.1 Storage conditions The delivered product should be stored with the conditions shown below;

Storage temperature : 10 to 30°C

Humidity : below 70%RH

The warranty term for the shipped product shall be for 1 year after shipping to the designated place by the ordered customer.

3.2 Treatment after open

- (1) After unsealed, devices should be mounted under the temperature condition of 10 to 30°C, at the humidity condition of below 70%RH, within 7days.
- (2) In case that long term storage is needed, devices should either be stored in dry box, or re-sealed to moist-proof bag with siccative and leave them in the environment where the temperature is 10 to 30°C, at the humidity condition of below 70%RH. Devices must be mounted within 2 weeks.

3.3 Baking before mounting

In the event that the devices are not maintained in the storage conditions described above, or the enclosed humidity indicator already turned its color to pink, baking must be applied before devices are to be mounted.

The case that Devices was not mounted under the temperature condition of 10 to 30°C at the humidity condition of below 70%RH or lower within 7 days, Baking process must be applied before devices are to be mounted.:

Please also note that baking should only be applied twice.

Recommended condition : ①100 to 110°C, 12 to 24 hours ②125°C, 6 to 24hours

※ Baking will not properly done in packing condition.

To complete the baking properly, devices should be placed to the metal tray.

Recommended condition of reel baking 60°C, 12 to 24hours

※ In the case of reel baking, hung the reel in the oven by passing the shaft in the center hole of reel.

Please avoid laying the reel.

3-4 Placement of reels in an oven

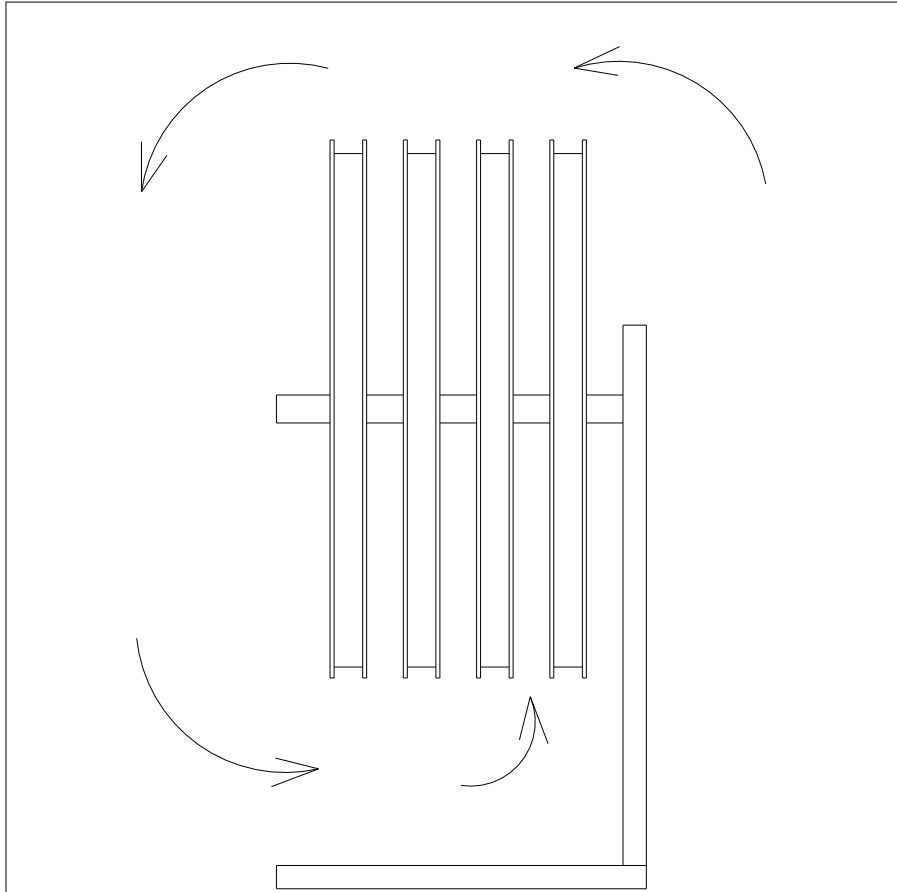

- 1) Please hang reels by using a center hole for fixing the reel.
Please keep some space between reels for better air rotation in the oven.
Please do not lay a reel down in the oven to avoid any damages for the tape edge and the flange of reel.
- 2) Please make sure the carrier tape does not have any slack in a reel before baking to avoid peeling the cover tape off.
Since the tape using for fixing carrier tape is not heatproof, there is a case to remain glue.
So if necessary, please change the tape to a heatproof one.

Packing

Inner Packing

① Inner Packaging drawing

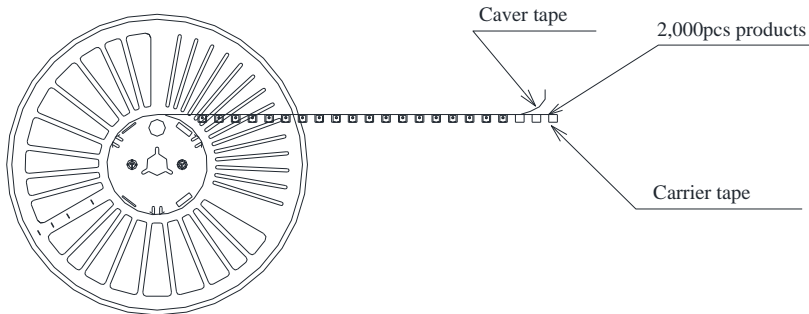

② Inner packing material: • Reel(PPE) • Carrier tape (PS) • Caver tape(PET)

③ Quantity :2,000pcs./Reel

Outer Packaging

① Outer Packaging drawing

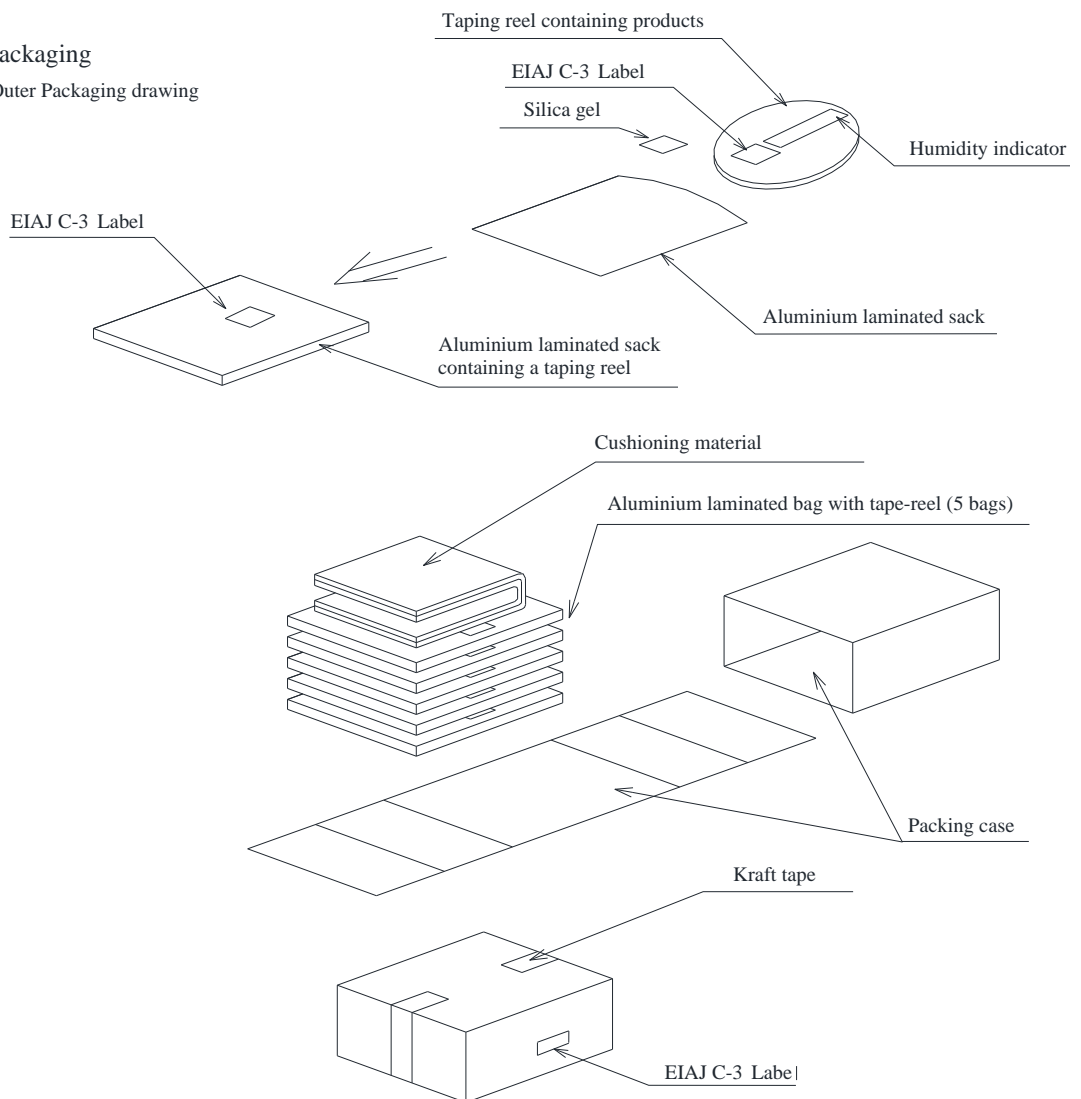

② Outer packing material: Packing case(Corrugated cardboard), Cushioning material (Urethane)

Aluminium laminated bag (Alumi-Polyethylene)

Humidity indicator card (paper), Label(paper), silica gel, craft tape

③ Quantity: 10,000pcs./box

④ The contents of the carton indication conforms to EIAJ C-3 and the following items are indicated.

Model No., Internal production control name, Quantity, Packing date, Corporate name, Country of origin

⑤ Regular packaged mass: Approximately 700g